



Urmia Tube & Profile Co.

شرکت لوله و پروفیل ارومیه



- PIPES / TUBES / PROFILES
- لوله / قوطی / پروفیل
- انابيب / مقاطع العلب المستطيلة و المربع / بروفیل



Urmia Tube & Profile Co.
شرکت لوله و پروفیل ارومیه

About Us

Orumieh Tube & Profile Co. One of the major producers of pipe and profiles in Iran, was established in 1997.

Products : Black industrial pipes, gas pipes , gas distribution pipes, square and rectangular profiles, door and window profiles and U and Z sections with an anual production capacity of 500000 tons.

Gas pipes are produced with Iran's standard (I.S.I.R. 3360) and according to API 5L and other products are produced according to DIN EN standards.

We supply the best raw materials to produce the best products in order to make all customers satisfy.

درباره ما

شرکت لوله و پروفیل ارومیه یکی از بزرگترین تولید کنندگان انواع لوله و پروفیل در ایران، در سال ۱۳۷۶ احداث شد. محصولات کارخانه شامل لوله‌های سیاه صنعتی ، لوله‌های گازخانگی و گاز رسانی شهری و قوطی های مربع و مستطیل ، پروفیل های درب و پنجره و پروفیل‌های صنعتی و مقاطع U و Z با ظرفیت تولید ۵۰۰ هزار تن در سال می‌باشد.

لوله‌های گازی با استاندارد ایران و کلیه محصولات مطابق با استاندارد API و DIN EN و با بهترین مواد اولیه تولید میشوند.

من نحن

شركة أورومیه للأنابيب والبروفيلات تأسست عام 1997. المنتجات: الأنابيب الصناعية السوداء ، وأنابيب الغاز ، وأنابيب توزيع الغاز ، والملاحح المربعة والمستطيلة ، ومقاطع الأبواب والنوافذ والأقسام U و Z بطاقة إنتاجية سنوية تبلغ 500000 طن. يتم إنتاج أنابيب الغاز وفقاً للمعايير الإيرانية (I.S.I.R. 3360) و وفقاً API 5L ويتم إنتاج المنتجات الأخرى وفقاً لمعايير DIN EN. نحن نوفر أفضل المواد الخام لإنتاج أفضل المنتجات من أجل إرضاء جميع العملاء.

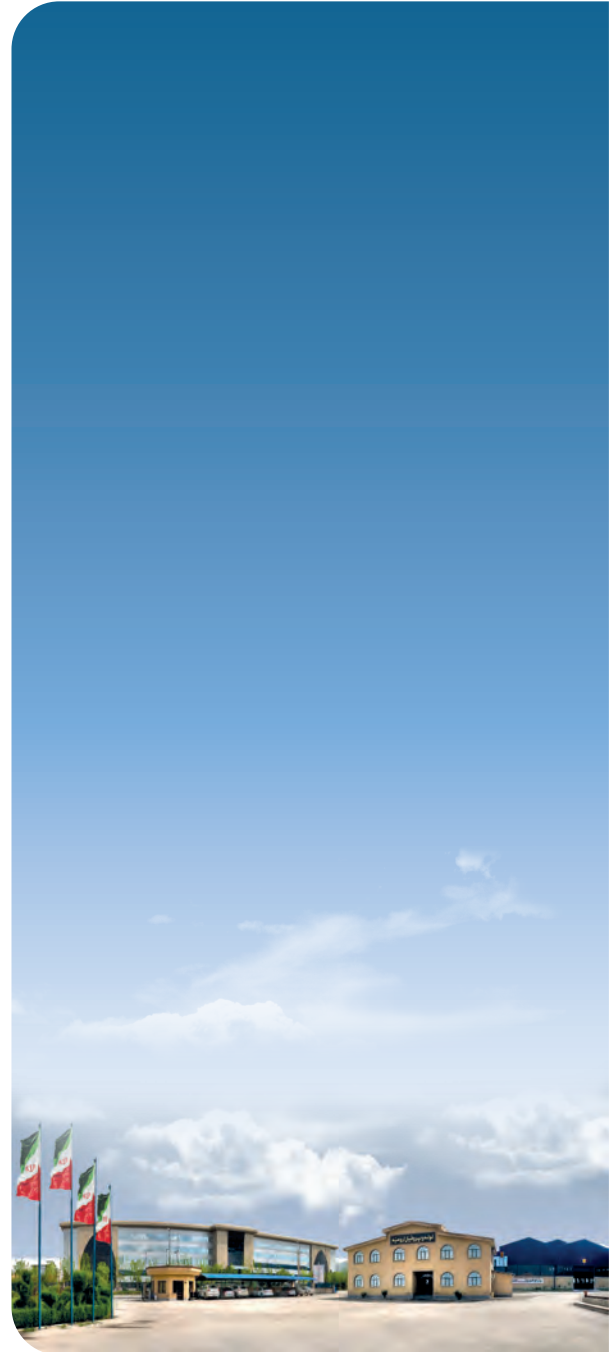

WWW.URMIASTEEL.COM
INFO@URMIASTEEL.COM



Urmia Tube & Profile Co.
شرکت لوله و پروفیل ارومیه



Awards and Certificates

گواهی های استاندارد و لوایح تقدیر
شواهدة جودة



CE / ISO 45001: 2018 / ISO10002 : 2015 / HSE MS

ISO 14001 : 2015 / OHSAS 18001: 2018 

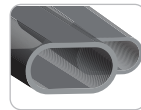
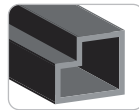
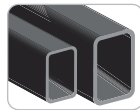
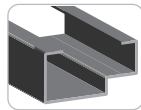
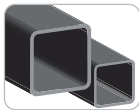
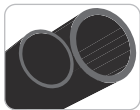



Gas Pipes

لوله‌های گازی

انابيب الغازی



Gas Pipes

According to (API 5L - 2007)

لوله‌های گازی انابیب الغازی

Nominal Size سایز اسمی	Outside Diameter قطر خارجی		Thickness ضخامت		Weight وزن
	(inch)	(inch) (mm)	(inch)	(mm)	
$\frac{3}{8}$	0/675	17/1	0/091	2/3	0/84
			0/126	3/2	1/10
$\frac{1}{2}$	0/840	21/3	0/109	2/8	1/28
			0/147	3/7	1/61
$\frac{3}{4}$	1/050	26/7	0/113	2/9	1/70
			0/154	3/9	2/19
1	1/315	33/4	0/133	3/4	2/52
			0/179	4/5	3/21
$1\frac{1}{4}$	1/660	42/2	0/140	3/6	3/43
			0/191	4/9	4/51
$1\frac{1}{2}$	1/900	48/3	0/145	3/7	4/07
			0/200	5/1	5/43
2	$2\frac{3}{8}$	60/3	0/083	2/1	3/01
			0.109	2/8	3/97
			0/125	3/2	4/51
			0/141	3/6	5/03
			0/154	3/9	5/42
			0/172	4/4	6/07
			0/188	4/8	6/57
3	$3\frac{1}{2}$	88/9	0/218	5/5	7/43
			0/125	3/2	6/76
			0/141	3/6	7/57
			0/156	4/0	8/37
			0/172	4/4	9/17
			0/188	4/8	9/95
			0/216	5/5	11/31
4	$4\frac{1}{2}$	114/3	0/250	6/4	13/02
			0/125	3/2	8/77
			0/141	3/6	9/83
			0/156	4/0	10/88
			0/172	4/4	11/92
			0/188	4/8	12/96
			0/203	5/2	13/99
			0/219	5/6	15/01
5	$5\frac{9}{16}$	141/3	0/237	6/0	16/02
			0/250	6/4	17/03
			0/125	3/2	10/90
			0/156	4/0	13/54
			0/188	4/8	16/16
			0/219	5/6	18/74
			0/258	6/6	21/92

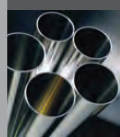

Gas Pipes

According to API 5L - 2007 Standard



Urmia Tube & Profile Co.
شرکت لوله و پروفیل ارومیه



Gas Pipes

According to (API 5L - 2007)

لوله‌های گازی
انابیب الغازی

Nominal Size سایز اسمی (inch)	Outside Diameter قطر خارجی (inch) (mm)		Thickness ضخامت (inch) (mm)		Weight وزن (kg)
	6	$6 \frac{5}{8}$	168.3	0.125	3.2
0.141				3.6	14.62
0.156				4.0	16.21
0.172				4.4	17.78
0.188				4.8	19.35
0.203				5.2	20.91
0.219				5.6	22.47
0.250				6.4	25.55
0.280				7.1	28.22
0.312				7.9	31.25
0.344				8.7	34.24
8				$8 \frac{5}{8}$	219.1
	0.188	4.8	25.37		
	0.203	5.2	27.43		
	0.219	5.6	29.48		
	0.250	6.4	33.57		
	0.277	7.0	36.61		
	0.312	7.9	41.14		
	0.322	8.2	42.65		
	0.344	8.7	45.14		
	0.375	9.5	49.10		
	0.438	11.1	56.94		
	0.500	12.7	64.64		
0.562	14.3	72.22			



Gas Pipes

According to API 5L - 2007 Standard





Urmia Tube & Profile Co.
شرکت لوله و پروفیل ارومیه



Gas Distributing Pipes (For Industrial and Household Uses)

لوله‌های گاز خانگی و صنعتی أنابيب الغاز المنزلية والصناعية

Nominal Size سایز اسمی	Outside Diameter قطر خارجی		Thickness ضخامت	Weight وزن
(inch)	(inch)	(mm)	(mm)	(kg)
15	$\frac{1}{2}$	21/3	2/65	1/22
20	$\frac{3}{4}$	26/9	2/65	1/58
25	1	33/7	3/25	2/44
32	$1\frac{1}{4}$	42/4	3/25	3/14
40	$1\frac{1}{2}$	48/3	3/25	3/61
50	2	60/3	3/65	5/10
65	$2\frac{1}{2}$	76/1	3/65	6/51
80	3	88/9	4/05	8/47
100	4	114/3	4/5	12/1
125	5	139/7	4/85	16/2
150	6	165/1	4/85	19/2



Gas Distributing Pipes (For Industrial and Household Uses)

لوله‌های گاز خانگی و صنعتی أنابيب الغاز المنزلية والصناعية





Urmia Tube & Profile Co.
شرکت لوله و پروفیل ارومیه



Water Pipes

According to (DIN EN 110219-2-1997)

لوله‌های انتقال آب (شوافازی)

أنابيب المياه

	Thickness (mm)											
	2	2.5	3	4	5	6	6.3	8	10	12	12.5	
Nominal Size سایز اسمی	Weight (kg) وزن											
21.3	0.95	1.16	1.35	-	-	-	-	-	-	-	-	-
26.9	1.23	1.5	1.77	-	-	-	-	-	-	-	-	-
33.7	1.56	1.92	2.27	-	-	-	-	-	-	-	-	-
42.4	1.99	2.46	2.91	3.79	-	-	-	-	-	-	-	-
48.3	2.28	2.82	3.35	4.37	5.34	-	-	-	-	-	-	-
60.3	2.88	3.56	4.24	5.55	6.82	-	-	-	-	-	-	-
76.1	3.65	4.54	5.41	7.11	8.77	10.4	10.8	-	-	-	-	-
88.9	4.29	5.33	6.36	8.38	10.3	12.3	12.8	-	-	-	-	-
101.6	4.91	6.11	7.29	9.63	11.9	14.1	14.8	-	-	-	-	-
114.3	-	6.89	8.23	10.9	13.5	16.0	16.8	21.0	-	-	-	-
139.7	-	-	10.1	13.4	16.6	19.8	20.7	26.0	32.0	-	-	-
168.3	-	-	12.2	16.2	20.1	24.0	25.2	31.6	39.0	-	-	-
177.8	-	-	-	17.1	21.3	25.4	26.6	33.5	41.4	49.1	51.0	-
193.7	-	-	-	18.7	23.3	27.8	29.1	36.6	45.3	53.8	55.9	-
219.1	-	-	-	21.2	26.4	31.5	33.1	41.6	51.6	61.3	63.7	-

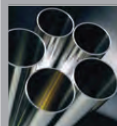

Water Pipes

According to (DIN EN 110219-2-1997)





Water Pipes

According to (DIN EN 110219-2-1997)

لوله‌های انتقال آب (شوفازی)

أنابيب المياه

Outside Diameter (mm) قطر خارجی القطر الخارجي			Thickness (mm)											
			2	2.3	2.6	2.9	3.2	3.6	4	4.5	5	5.4	5.6	6.3
Series 1	Series 2	Series 3	Weight (kg) وزن											
26.9			1.22	1.39	1.55	1.71	1.87	2.06	2.25	2.48	2.70	2.86	2.94	3.20
		30	1.38	1.57	1.75	1.93	2.11	2.34	2.56	2.82	3.08	3.27	3.36	3.80
	31.8		1.46	1.67	1.87	2.06	2.25	2.50	2.74	3.02	3.30	3.51	3.61	3.96
	32		1.47	1.68	1.88	2.08	2.27	2.52	2.76	3.05	3.32	3.54	3.64	3.99
33.7			1.56	1.78	1.99	2.20	2.40	2.67	2.92	3.24	3.53	3.76	3.88	4.25
		35	1.62	1.85	2.07	2.29	2.50	2.78	3.05	3.38	3.69	3.88	4.06	4.45
	38		1.77	2.02	2.26	2.51	2.76	3.05	3.35	3.71	4.06	4.32	4.47	4.92
	40		1.87	2.13	2.39	2.65	2.90	3.23	3.55	3.93	4.31	4.60	4.75	5.23
42.4			1.99	2.27	2.55	2.82	3.09	3.44	3.78	4.20	4.61	4.92	5.08	5.60
		44.5	2.09	2.39	2.68	2.97	3.25	3.63	3.99	4.43	4.87	5.20	5.37	5.93
48.3			2.28	2.60	2.93	3.24	3.55	3.96	4.36	4.86	5.33	5.71	5.89	6.52
	51		2.41	3.76	3.10	3.43	3.77	4.20	4.63	5.16	5.67	6.07	6.26	6.96
		54	2.56	2.93	3.29	3.65	4.00	4.47	4.93	5.49	6.04	6.47	6.68	7.41
	57		2.71	3.10	3.47	3.86	4.24	4.74	5.22	5.82	6.41	6.87	7.09	7.87
60.3			2.87	3.28	3.69	4.10	4.50	5.03	5.55	6.19	6.81	7.31	7.55	8.38
	53.5		2.53	2.90	3.26	3.62	3.96	4.42	4.88	5.43	5.98	6.40	6.61	7.33
	70		3.35	3.83	4.32	4.79	5.27	5.89	6.51	7.26	8.01	8.60	8.89	9.89
		73	3.50	3.83	4.51	5.01	5.78	6.16	6.80	7.60	8.38	9.00	9.30	10.36
76.1			3.65	4.18	4.71	5.23	5.75	6.43	7.11	7.94	8.76	9.41	9.73	10.84
		82.5	3.97	4.54	5.12	5.69	6.25	7.00	7.74	8.65	9.55	10.26	10.61	11.83
88.9			4.28	4.91	5.53	6.15	6.76	7.57	8.37	9.36	10.34	11.11	11.50	12.83
	101.6		4.91	5.63	6.34	7.05	7.76	8.70	9.62	10.77	11.91	12.81	13.25	14.80
		108	5.22	5.99	6.75	7.51	8.26	9.26	10.25	11.48	12.69	13.66	14.14	15.79
114.3			5.53	6.35	7.16	7.96	8.76	9.82	10.87	12.18	13.47	14.50	15.01	16.77
	127		6.16	7.07	7.97	8.87	9.76	10.95	12.13	13.59	15.04	16.19	16.76	18.75
	133		6.46	7.41	8.36	9.30	10.24	11.48	12.72	14.25	15.78	16.99	17.59	19.68
139.7			6.79	7.79	8.79	9.78	10.77	12.08	13.38	15.00	16.60	17.88	18.51	20.72
		141.3	6.87	7.88	8.89	9.89	10.89	12.22	13.54	15.18	16.80	18.09	18.73	20.97
		152.4	7.41	8.51	9.60	10.69	11.77	13.20	14.63	16.41	18.17	19.57	20.27	22.69
		159	7.74	8.88	10.02	11.16	12.29	13.79	15.28	17.14	18.98	20.45	21.18	23.73
138.3			6.72	7.71	8.70	9.68	10.66	11.95	13.24	14.86	16.43	17.69	18.32	20.50
		177.8	8.67	9.95	11.23	12.50	13.77	15.46	17.14	19.23	21.30	22.95	23.78	26.64
		193.7	9.45	10.85	12.25	13.64	15.03	16.87	18.71	20.99	23.26	25.07	25.97	29.11
219.1			10.70	12.29	13.88	15.46	17.03	19.13	21.21	23.81	26.39	28.45	29.48	33.06



Water Pipes

According to (DIN EN 10224:2002)



Urmia Tube & Profile Co.
شرکت لوله و پروفیل ارومیه



Water Pipes

According to (DIN EN 110219-2-1997)

لوله‌های انتقال آب (شوفازی)

أنابيب المياه

Outside Diameter (mm) قطر خارجی القطر الخارجي			Thickness (mm)													
			7.1	8	8.9	10	11	12.5	14.2	16	17.5	20	22.2	25		
Series 1	Series 2	Series 3	Weight (kg) وزن													
26/9			3.46	3.72	-	-	-	-	-	-	-	-	-	-	-	-
		30	4.00	4.34	-	-	-	-	-	-	-	-	-	-	-	-
	31/8		4.32	4.69	-	-	-	-	-	-	-	-	-	-	-	-
	32		4.35	4.73	5.06	-	-	-	-	-	-	-	-	-	-	-
33/7			4.65	5.07	5.44	-	-	-	-	-	-	-	-	-	-	-
		35	4.88	5.32	5.72	6.16	6.51	-	-	-	-	-	-	-	-	-
	38		5.41	5.91	6.38	6.90	7.32	-	-	-	-	-	-	-	-	-
	40		5.76	6.31	6.82	7.39	7.86	-	-	-	-	-	-	-	-	-
42/4			6.18	6.78	7.35	7.98	8.61	-	-	-	-	-	-	-	-	-
		44/5	6.54	7.20	7.81	8.50	9.08	9.86	-	-	-	-	-	-	-	-
48/3			7.21	7.95	8.64	9.44	10.11	11.03	-	-	-	-	-	-	-	-
	51		7.68	8.48	9.23	10.11	10.57	11.68	-	-	-	-	-	-	-	-
		54	8.21	9.07	9.89	10.85	11.66	12.79	13.93	-	-	-	-	-	-	-
	57		8.73	9.66	10.55	11.59	12.47	13.71	14.98	-	-	-	-	-	-	-
60/3			9.31	10.31	11.28	12.40	13.37	14.73	16.14	-	-	-	-	-	-	-
	53/5		8.12	8.97	9.78	10.72	11.52	12.63	13.76	14.79	-	-	-	-	-	-
	70		11.01	12.23	13.40	14.79	16.00	17.72	19.53	21.30	-	-	-	-	-	-
		73	11.53	12.82	14.06	15.53	16.81	18.64	20.59	22.48	23.95	-	-	-	-	-
76/1			12.08	13.43	14.74	16.30	17.65	19.60	21.67	23.71	25.28	-	-	-	-	-
		82/5	13.20	14.69	16.15	17.87	19.39	21.57	23.91	26.23	28.05	30.82	-	-	-	-
88/9			14.33	15.95	17.55	19.45	21.13	23.55	26.15	28.76	30.81	3.98	-	-	-	-
	101/6		16.54	18.46	20.34	22.58	24.57	27.46	30.60	33.77	36.29	40.24	43.88	-	-	-
		108	17.66	19.72	21.74	24.16	26.31	29.43	32.84	36.29	39.05	43.40	46.97	58.16	-	-
114/3			18.76	20.97	23.13	25.72	28.2	31.37	35.05	38.78	41.77	46.50	57.37	55.05	-	-
	127		20.99	23.47	25.91	28.85	31.46	35.29	39.49	43.79	47.25	52.77	57.37	62.88	-	-
	133		22.04	24.66	27.23	30.33	33.9	37.14	41.60	46.16	49.84	55.73	60.65	66.58	-	-
139/7			23.21	25.98	28.70	31.98	34.91	39.20	43.94	48.80	52.73	59.03	64.32	70.71	-	-
		141/3	23.49	26.29	29.05	32.37	35.34	39.70	44.50	49.43	53.42	59.82	65.20	71.69	-	-
		152/4	25.43	28.48	31.49	35.11	38.35	43.12	48.39	53.81	58.21	69.29	71.27	78.54	-	-
		159	26.59	29.78	32.94	36.74	40.14	45.15	50.70	56.42	61.06	68.55	74.19	82.61	-	-
138/3			22.97	25.70	28.39	31.63	34.53	38.77	43.45	48.29	52.13	58.34	63.55	69.84	-	-
		177/8	29/88	33/49	37/06	41/37	45/24	50.95	57.28	63.83	69.17	77.82	85.18	94.20	-	-
		193.7	32/67	36/63	40/55	45/30	49/55	55/85	62/85	70/11	76.03	85.66	93.88	104.00	-	-
219/1			37/11	41/64	46/13	51/56	56/44	63/68	71/75	80/13	87.00	98.19	107.79	119.66	-	-



Water Pipes

According to (DIN EN 10224:2002)



Urmia Tube & Profile Co.
شرکت لوله و پروفیل ارومیه

Industrial Pipes

لوله‌های صنعتی
الانابيب الصناعية

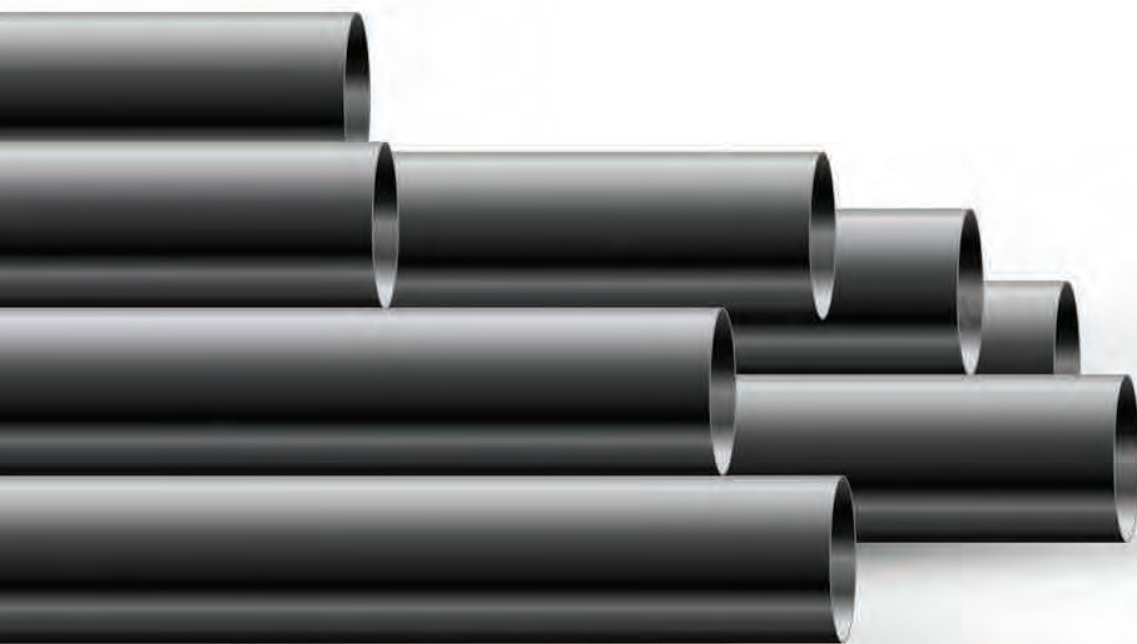

According to
DIN EN 10305-2003



Urmia Tube & Profile Co.
شرکت لوله و پروفیل ارومیه



Industrial Tubes

According to (DIN EN 10305-3-2003)

لوله‌های صنعتی
الانابیب الصناعیة

Nominal Size (mm) سایز اسمی حجم الاسمی	Thickness (mm)															
	0/6	0/8	1	1/2	1/5	1/8	2	2/2	2/5	3	3/5	4	4/5	5	5/5	6
	Weight (kg) وزن															
12	0/168	0/221	0/271	0/320	0/398	0/453	0/493	-	-	-	-	-	-	-	-	-
15	0/213	0/280	0/345	0/408	0/499	0/585	0/641	0/694	-	-	-	-	-	-	-	-
16	0/227	0/299	0/369	0/437	0/536	0/630	0/690	0/748	-	-	-	-	-	-	-	-
18	0/257	0/339	0/419	0/497	0/610	0/719	0/789	0/956	-	-	-	-	-	-	-	-
19	0/272	0/359	0/469	0/556	0/684	0/808	0/888	0/966	1/08	1/26	-	-	-	-	-	-
20	0/287	0/379	0/592	0/704	0/869	1/03	1/13	1/24	1/39	1/63	-	-	-	-	-	-
22	0/316	0/418	0/513	0/616	0/758	0/897	0/986	1/07	1/20	1/41	-	-	-	-	-	-
25	0/361	0/477	0/592	0/704	0/869	1/03	1/13	1/24	1/39	1/63	-	-	-	-	-	-
28	0/405	0/536	0/665	0/793	0/980	1/16	1/28	1/39	1/57	1/84	2/11	-	-	-	-	-
30	0/435	0/576	0/715	0/852	1/05	1/25	1/38	1/51	1/7	2/00	2/29	-	-	-	-	-
32	-	0/615	0/765	0/911	1/13	1/34	1/48	1/62	1/82	2/15	2/46	-	-	-	-	-
35	-	-	0/838	1/00	1/24	1/47	1/63	1/78	2/00	2/37	2/72	-	-	-	-	-
38	-	-	0/912	1/09	1/35	1/61	1/78	1/94	2/19	2/59	2/98	3/35	-	-	-	-
40	-	-	0/962	1/15	1/42	1/70	1/87	2/05	2/31	2/74	3/15	3/55	-	-	-	-
42	-	-	1/01	1/20	1/49	1/78	1/97	2/15	2/43	2/88	3/32	3/74	-	-	-	-
42/4	-	-	1/02	1/21	1/51	1/80	1/99	2/18	2/45	2/91	3/35	3/87	-	-	-	-
44	-	-	1/06	1/26	1/57	1/87	2/07	2/26	2/55	3/03	3/49	3/94	-	-	-	-
45	-	-	1/9	1/30	1/61	1/92	2/12	2/32	2/62	3/11	3/58	4/04	-	-	-	-
48/3	-	-	1/11	1/39	1/73	2/06	2/28	2/50	2/82	3/35	3/86	3/36	4/86	-	-	-
50	-	-	1/21	1/44	1/79	2/14	2/37	2/59	2/93	3/48	4/01	4/54	5/05	-	-	-
51	-	-	-	1/47	1/83	2/18	2/41	2/64	2/99	3/55	4/09	4/63	5/16	-	-	-
55	-	-	-	1/55	1/98	2/36	2/61	2/86	3/24	3/85	4/45	5/03	5/60	-	-	-
57	-	-	-	1/65	2/05	2/45	2/71	2/97	3/35	3/99	4/61	5/22	5/82	-	-	-
60	-	-	-	1/74	2/16	2/58	2/86	3/14	3/55	4/22	4/88	5/52	6/16	6/78	7/39	-
63/5	-	-	-	1/84	2/29	2/73	3/03	3/32	3/76	4/47	5/17	5/86	6/54	7/21	7/86	-
70	-	-	-	2/04	2/53	3/03	3/35	3/68	4/16	4/96	5/74	6/51	7/27	8/01	8/75	-
76	-	-	-	2/21	2/75	3/29	3/64	4/00	4/53	5/40	6/25	7/10	7/93	8/75	9/56	-
80	-	-	-	2/33	2/90	3/47	3/85	4/22	4/78	5/70	6/60	7/50	8/38	9/25	10/1	-
89	-	-	-	-	3/23	3/87	4/29	4/70	5/33	6/36	7/37	8/38	9/37	10/35	11/32	12/28
90	-	-	-	-	3/27	3/92	4/34	4/76	5/39	6/44	7/47	8/48	9/49	10/5	11/5	12/4
100	-	-	-	-	3/46	4/36	4/83	5/31	6/01	7/18	8/33	9/47	10/6	11/7	12/8	13/9
101/6	-	-	-	-	3/70	4/42	4/91	5/39	6/10	7/29	8/46	9/62	10/77	11/91	13/03	14/14
108	-	-	-	-	3/94	4/73	6/23	5/74	6/50	7/77	9/02	10/3	11/5	12/7	13/9	15/1
114	-	-	-	-	-	4/98	5/52	6/20	6/87	8/21	9/54	10/9	12/2	13/4	14/7	16/0
120	-	-	-	-	-	5/24	5/82	6/39	7/24	8/66	10.1	11/4	12/8	14/2	15/5	16/9
127	-	-	-	-	-	5/55	6/16	6/77	7/67	9/17	10/65	12/13	13/59	15/04	16/47	17/90
133	-	-	-	-	-	5/82	6/46	7/10	8/05	9/62	11/2	12/7	14/3	15/8	17/3	18/9
139/7	-	-	-	-	-	6/12	6/79	7/45	8/45	10/11	11/75	13/38	15/00	16/60	18/20	19/78
159	-	-	-	-	-	6/98	7/74	8/51	9/65	11/5	13/4	15/3	17/2	19/0	20/6	22/6
168	-	-	-	-	-	7/33	8/18	8/99	10/20	12/20	14/19	16/17	18/14	20/09	22/03	23/96
193/7	-	-	-	-	-	-	-	10/38	11/78	14/10	16/41	18/71	20/99	23/26	25/52	27/77



Industrial Tubes

According to (DIN EN 10305-3-2003)



Urmia Tube & Profile Co.
شرکت لوله و پروفیل ارومیه



Industrial Tubes

According to (DIN EN 10305-3-2003)

لوله‌های صنعتی
الانابیب الصناعیة

Nominal Size (mm) سایز اسمی دجم الاسمی	Thickness (mm)														
	1	1.25	1.40	1.50	1.60	1.75	1.80	2	2.30	2.50	2.60	2.90	3	3.20	3.50
	Weight (kg) وزن														
165.1	-	-	-	-	-	-	-	8.125	9.327	10.125	10.523	11.715	12.112	12.903	14.087
168	-	-	-	-	-	-	-	8.268	9.492	10.305	10.712	11.925	12.328	13.135	14.34
168.3	-	-	-	-	-	-	-	8.283	9.51	10.323	10.73	11.947	12.352	13.158	14.367
177.8	-	-	-	-	-	-	-	-	-	-	-	12.490	12.916	13.767	15.042
193.7	-	-	-	-	-	-	-	-	-	-	-	13.621	14.086	15.015	16.407
219.1	-	-	-	-	-	-	-	-	-	-	-	15.408	15.935	16.987	18.564

Nominal Size (mm) سایز اسمی دجم الاسمی	Thickness (mm)													
	3.60	3.70	3.80	4	4.50	5	5.60	5.80	6	6.3	7.1	8	8.8	10.1
	Weight (kg) وزن													
165.1	14.48	14.873	15.267	16.05	18	19.933	22.25	23.017	23.783	24.518	27.90	31.324	34.347	39.216
168	14.74	15.142	15.54	16.338	18.333	20.3	22.65	23.433	24.217	25.277	28.398	31.886	34.965	39.925
168.3	14.768	15.168	15.568	16.368	18.367	20.333	22.7	23.483	24.25	25.326	28.454	31.948	35.033	40.0
177.8	15.466	15.890	16.313	17.160	19.269	21.372	23.884	24.719	25.552	26.80	-	-	-	-
193.7	16.87	17.333	17.795	18.72	21.024	23.322	26.068	26.981	27.892	29.257	32.884	36.94	40.525	-
219.1	19.88	19.613	20.137	21.184	23.797	26.403	29.518	30.555	31.14	33.14	37.259	41.87	45.947	52.53

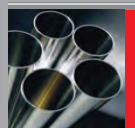

Industrial Tubes

According to (DIN EN 10305-3-2003)

لوله‌های صنعتی
الانابیب الصناعیة





Urmia Tube & Profile Co.
شرکت لوله و پروفیل ارومیه

Rectangular & Square Tubes

قوٹی های مربع و مستطیل
مقاطع العلب المستطیلة و المربع



According to
DIN EN 10305-2003



Urmia Tube & Profile Co.
شرکت لوله و پروفیل ارومیه

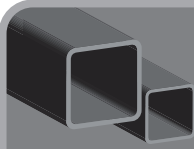

Square Tubes

According to (D IN EN 10219 - 2 - 1997)

قوسی های مربع
مقاطع العلب المربع

Nominal Size (mm) سایز اسمی دجم الاسمی	Thickness (mm)												
	2	2.5	3	4	5	6	6.3	8	10	12	12.5	16	
	Weight (kg) وزن												
20 x 20	1.05	-	-	-	-	-	-	-	-	-	-	-	-
25 x 25	1.36	1.64	1.89	-	-	-	-	-	-	-	-	-	-
30 x 30	1.68	2.03	2.36	-	-	-	-	-	-	-	-	-	-
40 x 40	2.31	2.82	3.30	4.20	-	-	-	-	-	-	-	-	-
50 x 50	2.93	3.60	4.25	5.45	6.56	-	-	-	-	-	-	-	-
60 x 60	3.56	4.39	5.19	6.71	8.13	9.45	9.55	-	-	-	-	-	-
70 x 70	-	5.17	6.13	7.97	9.70	11.3	11.5	-	-	-	-	-	-
80 x 80	-	-	7.07	9.22	11.3	13.2	13.5	16.4	-	-	-	-	-
90 x 90	-	-	8.01	10.5	12.8	15.1	15.5	18.9	-	-	-	-	-
100 x 100	-	-	8.96	11.7	14.4	17.0	17.5	21.4	25.6	28.3	29.1	-	-
120 x 120	-	-	10.8	14.2	17.5	20.7	21.4	26.4	31.8	35.8	36.9	-	-
140 x 140	-	-	-	16.8	20.7	24.5	25.4	31.4	38.1	43.4	44.8	-	-
150 x 150	-	-	-	18.0	22.3	26.4	27.4	33.9	41.3	47.1	48.7	58.7	-
160 x 160	-	-	-	19.3	23.8	28.3	29.3	36.5	44.4	50.9	52.6	63.7	-
180 x 160	-	-	-	21.8	27.0	32.1	33.3	41.5	50.7	58.5	60.5	73.8	-
200 x 200	-	-	-	24.3	30.1	35.8	37.2	46.5	57.0	66.0	68.3	83.8	-
220 x 220	-	-	-	-	33.2	39.6	41.2	51.5	63.2	73.5	76.2	93.9	-

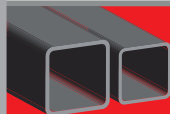

Square Tubes

According to (D IN EN 10219 - 2 - 1997)





Urmia Tube & Profile Co.
شرکت لوله و پروفیل ارومیه

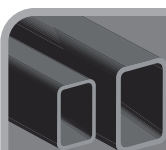

Rectangular Tubes

According to (DIN 2395 Part 3)

قوسی های مستطیل شکل
مقاطع العلب المستطیل

Nominal Size (mm) سایز اسمی حجم الاسمی	Thickness (mm)							
	1	1.5	2	2.5	3	4	5	6
	Weight (kg) وزن							
20x10	0.423	0.598	-	-	-	-	-	-
20x15	0.501	0.716	-	-	-	-	-	-
25x15	0.580	0.833	-	-	-	-	-	-
25x20	0.658	0.951	1.22	-	-	-	-	-
30x15	0.658	0.951	-	-	-	-	-	-
30x20	0.737	1.07	1.38	1.66	1.92	-	-	-
30x25	0.815	1.19	1.53	1.86	2.16	-	-	-
35x20	0.815	1.19	1.53	1.86	-	-	-	-
35x25	0.894	1.30	1.69	2.05	-	-	-	-
35x30	-	1.42	1.85	2.25	2.63	-	-	-
40x20	0.894	1.30	1.69	2.05	2.39	-	-	-
40x25	-	1.42	1.85	2.25	2.63	-	-	-
40x30	1.05	1.54	2.00	2.45	2.86	-	-	-
40x35	-	1.66	2.16	2.64	3.10	-	-	-
45x25	-	1.54	2.00	2.45	2.86	-	-	-
45x30	-	1.66	2.16	2.64	3.10	-	-	-
45x35	-	1.78	2.32	2.84	3.33	-	-	-
45x40	-	1.89	2.48	3.03	3.57	4.57	-	-
50x25	-	1.66	2.16	2.64	3.10	-	-	-
50x30	-	1.78	2.32	2.84	3.33	-	-	-
50x35	-	1.89	2.48	3.03	3.57	-	-	-
50x40	-	2.01	2.63	3.23	3.80	4.88	-	-
55x35	-	2.01	2.63	3.23	3.80	-	-	-
60x25	-	1.89	2.48	3.03	-	-	-	-
60x30	-	2.01	2.63	3.23	3.80	-	-	-
60x40	-	2.25	2.95	3.63	4.28	5.51	-	-
60x50	-	2.48	3.26	4.02	4.75	6.14	7.34	-
70x30	-	-	2.95	3.62	4.28	-	-	-
70x40	-	-	3.26	4.02	4.75	6.14	-	-
70x50	-	-	3.57	4.41	5.22	6.76	8.13	-
70x60	-	-	3.89	4.80	5.69	7.39	8.91	10.4
80x40	-	-	3.57	4.41	5.22	6.76	-	-
80x50	-	-	3.89	4.8	5.69	7.39	8.91	-
80x60	-	-	4.20	8.9	6.16	8.02	9.70	11.3
90x50	-	-	4.20	-	6.16	8.02	9.70	-
90x60	-	-	4.52	-	6.63	8.65	10.5	12.3
100x40	-	-	4.20	-	6.16	8.02	-	-
100x50	-	-	4.52	-	6.63	8.65	10.5	-
100x60	-	-	-	-	7.10	9.28	11.3	13.2
100x80	-	-	-	-	8.04	10.5	12.8	15.1
110x70	-	-	-	-	8.04	10.5	12.8	15.1
120x40	-	-	-	5.98	7.10	9.28	11.3	13.2
120x50	-	-	-	-	7.57	9.90	12.1	14.2
120x60	-	-	-	-	8.04	10.5	12.8	15.1
120x80	-	-	-	-	8.99	11.8	14.4	17.0

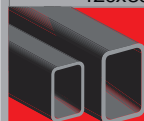

Rectangular Tubes

According to (DIN 2395 Part 3)



Urmia Tube & Profile Co.
شرکت لوله و پروفیل ارومیه

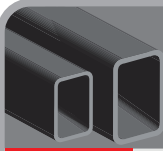

Rectangular Tubes
According to (DIN 2395 Part 3)

قوٹی های مستطیل شکل
مقاطع العلب المستطیل

Nominal Size (mm) سایز اسمی دجم الاسمی	Thickness (mm)																								
	0.9	1	1.25	1.40	1.50	1.60	1.75	1.80	2	2.30	2.50	2.60	2.90	3	3.20	3.50	3.60	3.70	3.80	4	4	5	5.60	5.80	6
	Weight (kg) وزن																								
120x100	-	-	-	-	-	4.59	-	-	7.045	8.083	8.873	9.118	10.148	10.49	11.173	12.193	12.533	12.872	13.21	13.885	15.563	17.233	19.217	19.897	20.517
140x40	-	-	-	-	4.307	-	5.013	5.155	5.717	6.557	7.115	7.393	8.223	8.5	9.05	9.872	10.143	10.417	10.688	11.23	12.577	13.91	15.493	16.017	16.53
140x60	-	-	-	-	-	-	5.595	5.752	6.38	7.32	7.943	8.255	9.185	9.495	10.112	11.032	11.338	11.643	11.948	12.557	14.07	15.568	17.35	17.95	18.53
140x80	-	-	-	-	-	-	-	-	7.045	8.083	8.773	9.118	10.148	10.49	11.173	12.193	12.533	12.872	13.21	13.885	15.563	17.233	19.217	19.867	20.51
140x100	-	-	-	-	-	-	-	-	7.657	8.788	9.54	9.915	11.037	11.408	12.153	13.265	13.635	14.005	14.373	15.11	16.950	18.767	20.933	21.65	22.36

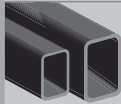

Rectangular Tubes
According to (DIN 2395 Part 3)

قوٹی های مستطیل شکل
مقاطع العلب المستطیل

Nominal Size (mm) سایز اسمی دجم الاسمی	Thickness (mm)																		
	3	3.2	3.5	3.6	3.7	3.8	4	4.5	5	5.6	5.8	6	6.30	7.1	8	10	12.5	14	
	Weight (kg) وزن																		
200x120	14.695	15.674	17.144	17.634	18.124	18.613	19.593	22.042	24.492	27.431	28.41	29.39	30.859	34.778	39.187	48.984	61.23	-	
240x120	-	-	-	-	-	-	-	24.113	26.793	30.0	31.079	32.151	33.759	38.046	42.868	53.586	66.982	75.020	

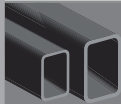

Rectangular Tubes
According to (DIN 2395 Part 3)

قوٹی های مستطیل شکل
مقاطع العلب المستطیل





Urmia Tube & Profile Co.
شرکت لوله و پروفیل ارومیه

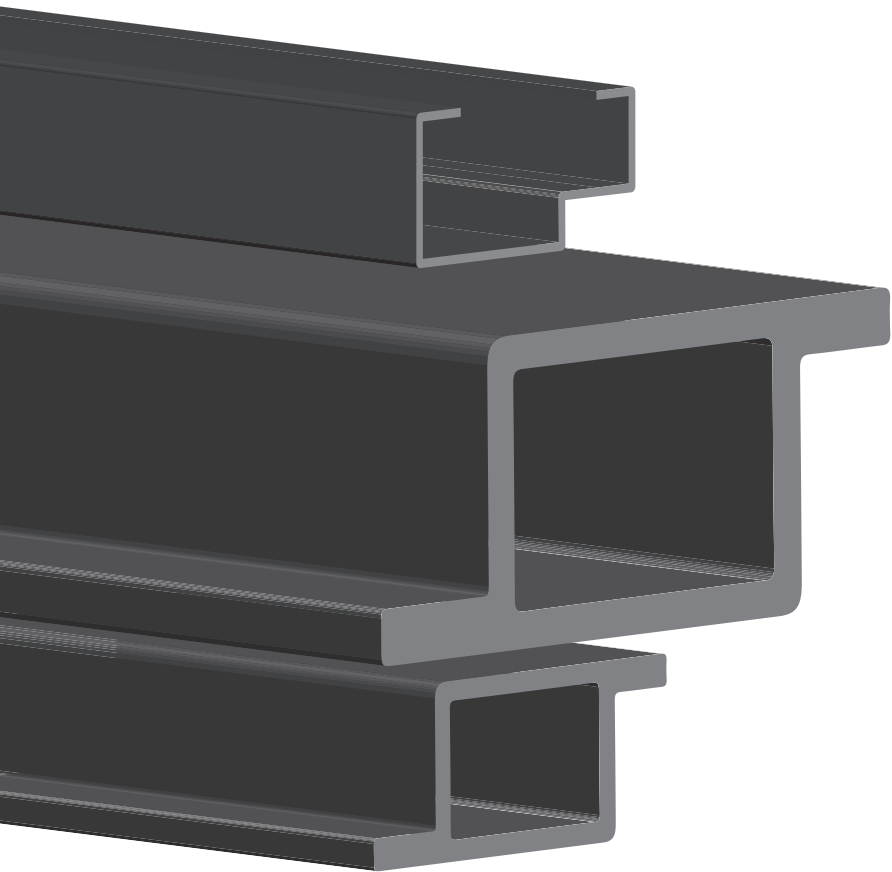

Door and Window Profiles

پروفیل های درب و پنجره

مقاطع الابواب و النوافذ

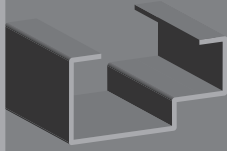

Door and Window Profiles

پروفیل های درب و پنجره
مقاطع الابواب و النوافذ

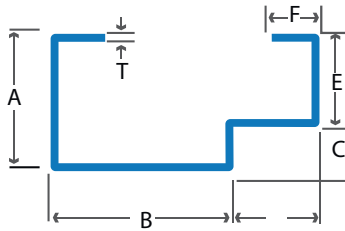

Profile No.	Dimensions (mm)						Thickness (mm)	
	A	B	C	D	E	F	1/8	2/00
86-1	50	85	18	35	32	15	3/215	3/572
86-8	50	105	18	35	32	15	3/440	3/822

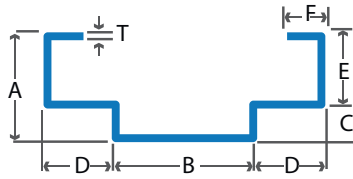

Profile No.	Dimensions (mm)						Thickness (mm)	
	A	B	C	D	E	F	1/8	2/00
86-9	50	90	18	35	32	15	3/692	4/103

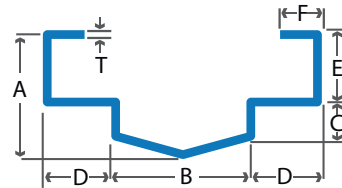

Profile No.	Dimensions (mm)						Thickness (mm)	
	A	B	C	D	E	F	1/8	2/00
86-10	5/57	90	18	35	32	15	3/130	4/479

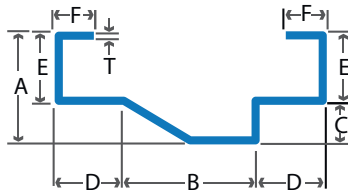

Profile No.	Dimensions (mm)						Thickness (mm)	
	A	B	C	D	E	F	1/8	2/00
86-11	45	70	15	35	30	15	3/215	3/572



Profile No.	Dimensions (mm)				Thickness (mm)	
	A	B	C	D	8/1	00/2
12-86	50	25	25	18	303/2	559/2

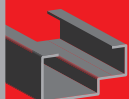

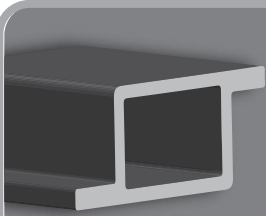

Door and Window Profiles

پروفیل های درب و پنجره
مقاطع الابواب و النوافذ

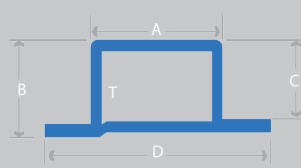

Profile No :
458
554
577
604
635
704
764

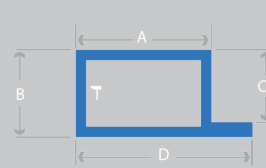

Profile No :
459
509
501
551
571
606
703

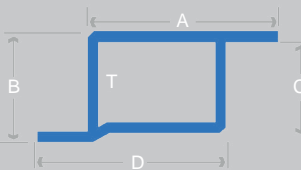

Profile No :
459
555
579
603
631
706
766

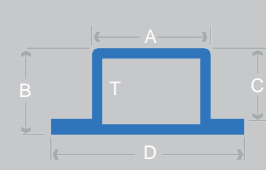

Profile No :
456
507
552
602
638
702
762

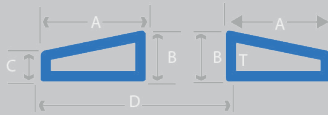

Profile No :
191
222
252
94
95
87

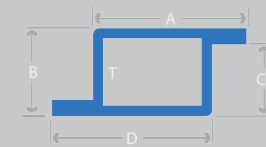

Profile No :
457
508
576
601
633
701
761

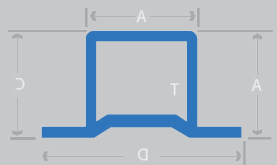

Profile No :
654

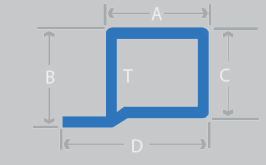

Profile No :
559

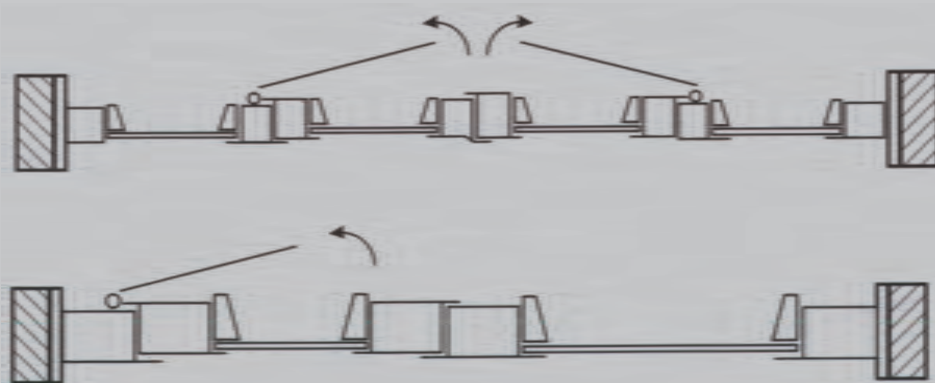

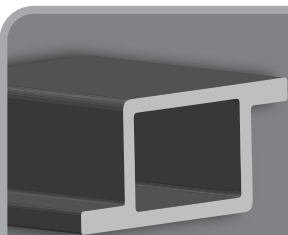

Door and Window Profiles

پروفیل های درب و پنجره
مقاطع الابواب و النوافذ

Group	Profile No:	Dimension (mm)				Thickness (mm)		
		A	B	C	D	T=1/5	T=1/8	T=2/00
1	4591	30	29	25.5	40	1.63	1.94	-
	456	22	29	25.5	42	1.63	1.94	-
	457	32	29	25.5	32	1.63	1.94	-
	458	20	33.5	25.5	40	1.63	1.94	-
	459	30	33.5	25.5	30	1.63	1.94	-
	191	22	10	6	-	0.660	0.840	-
	94	21	10	6	-	0.660	0.840	-
2	509	38	29	25	51	-	2.2	2.44
	507	25	29	25	51	-	2.2	2.44
	508	38	29	25	38	-	2.2	2.44
	554	29	33	25	55	-	2.39	2.64
	555	42	33	25	42	-	2.39	2.64
	222	25	11	7	-	-	0.91	1.00
	95	25	11	7	-	-	0.91	1.00
3	501	31	34	30	46	-	2.2	2.44
	552	23	34	30	53	-	2.39	2.64
	576	41	34	30	41	-	2.48	2.74
	577	23	38	30	53	-	2.48	2.74
	579	38	38	30	38	-	2.48	2.74
	252	27	15	30	-	-	1.040	1.15
	87	28	15	8	-	-	1.025	1.123
4	551	37	34	30	52	-	2.39	2.64
	602	31	34	30	61	-	2.61	2.89
	601	46	34	30	46	-	2.61	2.89
	604	29	38	30	59	-	2.61	2.89
	603	44	38	8	44	-	2.61	2.89
	252	27	15	8	-	-	1.04	1.15
	87	28	15	11	-	-	-	1.123
5	571	40	34	30	55	-	-	2.74
	638	36	34	30	66	-	-	3.100
	633	51	34	30	51	-	-	3.100
	635	33	38	30	63	-	-	3.100
	631	48	38	30	48	-	-	3.100
	252	27	15	30	-	-	-	1.150
	87	28	15	8	-	-	-	1.123
6	606	46	34	30	61	-	-	2.977
	702	44	34	30	74	-	-	3.390
	701	59	34	30	59	-	-	3.390
	704	42	38	30	72	-	-	3.390
	706	57	38	30	57	-	-	3.390
	252	27	15	8	-	-	-	1.150
	87	28	15	11	-	-	-	1.123
7	703	59	34	30	74	-	-	3.39
	762	55	34	30	85	-	-	3.69
	761	70	34	30	70	-	-	3.69
	764	53	38	30	83	-	-	3.69
	766	68	38	30	68	-	-	3.69
	252	27	15	8	-	-	-	1.150
	87	28	15	11	-	-	-	1.123
8	559	35	38	34	50	-	-	2.84
	604	29	34	30	59	-	-	2.89
	603	44	34	30	44	-	-	2.89
	635	33	34	30	63	-	-	3.100
	654	33	38	34	63	-	-	3.100
	252	27	15	8	-	-	-	1.150
	87	28	15	11	-	-	-	1.123



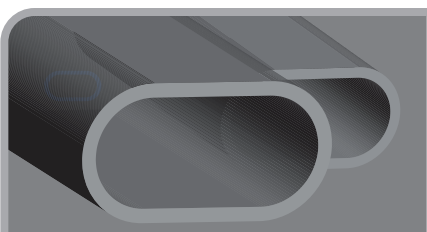

Precision Tube of Flat Oval Cross

لوله های دقیق بیضی شکل مسطح
أنابيب بیضایه مسطحة

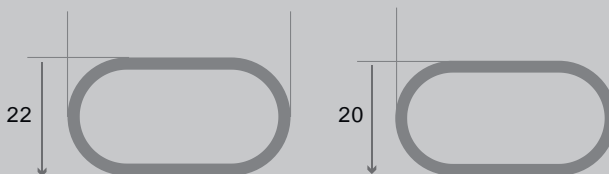

Dimensions ابعاد أبعاد	Thickness (mm)			
	1	1.5	2	2.5
	Weight (Kg/m) وزن			
20 x 40	0.76	1.13	1.48	1.82
22 x 37.5	0.76	1.13	1.48	1.82



Industrial Formed Profiles

Profile No: شماره پروفیل رقم البروفیل	Thickness (mm)															
	1.50	1.60	1.75	1.80	2	2.30	2.50	2.60	2.90	3	3.20	3.50	3.60	3.70	3.80	4
	Weight (Kg/m) وزن															
9001	3.347	3.565	3.893	4.002	4.437	5.083	5.513	5.727	6.365	6.577	7.000	7.628	7.838	8.047	8.253	8.668
7001	2.622	2.793	3.048	3.133	3.472	3.975	4.307	4.473	4.967	5.130	5.455	5.940	6.102	6.262	6.420	6.738
6003	2.240	2.385	2.602	2.674	2.961	3.387	3.669	3.809	4.226	4.364	4.639	5.047	5.182	5.317	5.451	5.717
6002	2.240	2.385	2.602	2.674	2.961	3.387	3.669	3.809	4.226	4.364	4.639	5.047	5.182	5.317	5.451	5.717
6001	2.240	2.385	2.602	2.674	2.961	3.387	3.669	3.809	4.226	4.364	4.639	5.047	5.182	5.317	5.451	5.717

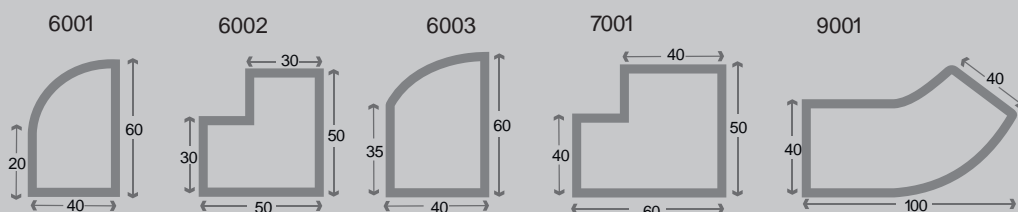



Urmia Tube & Profile Co.

شرکت لوله و پروفیل ارومیه

2nd Industrial zone, Urmia - Iran

Tel :+98 44 3374 4220 - 24

Tel :+98 44 3374 5055 - 58

Fax :+98 44 3374 4628

Sales :+98 44 3374 4623

آدرس : ارومیه، شهرک صنعتی فاز ۲

تلفن : ۲۴ - ۴۲۲۰ - ۳۳۷۴ - ۴۴

تلفن : ۵۸ - ۵۵ - ۵۰ - ۳۳۷۴ - ۴۴

فکس : ۴۶۲۸ - ۳۳۷۴ - ۴۴

واحد فروش : ۲۳ - ۴۶۲۰ - ۳۳۷۴ - ۴۴

العنوان : ایران - ارومیا ، مدینه الصناعیه الثانی

الهاتف : ۲۴ - ۴۲۲۰ - ۳۳۷۴ - ۹۸۴۴+

الهاتف : ۵۸ - ۵۵ - ۵۰ - ۳۳۷۴ - ۹۸۴۴+

فاکس : ۴۶۲۸ - ۳۳۷۴ - ۹۸۴۴+

قسم المبيعات : ۴۶۲۳ - ۳۳۷۴ - ۹۸۴۴+



+98 914 449 6902



+98 914 449 6903



www.urmiasteel.com



info@urmiasteel.com



sales@urmiasteel.com